



Design data sheet

No. 20

Design of CSP Manhole Risers

Issued: March 2002

This Data Sheet is for general use only and should not be used without first securing competent engineering advice as to its suitability for any specific application. The publication of this material is not intended as a representation or warranty on the part of the National Corrugated Steel Pipe Association that such data and information are suitable for any general or particular use or of freedom from infringement of any patent(s). Neither NCSA nor any of its members warrants or assumes liability as to its suitability for any given application. Anyone using this data sheet assumes all liability arising from such use. ■ *Design Data Sheets are for guidance only. They require an experienced P.E. for proper installation.*

Design of CSP Manhole Risers

Manhole Details

CSP manholes can be fabricated in various forms to meet project requirements. Figures 1 and 2 show two types that may be used. The riser-type shown in Figure 1 is generally used for main line diameters of 48-in. or more. The shaft-type manhole shown in Figure 2 is generally used for smaller diameters, and is also advantageous where changes are made in the main line diameter or alignment. Shaft type manholes can be placed on a reinforced concrete slab as illustrated in Figure 3.

With the riser-type manhole, the riser is usually aligned with the outside of the main pipe rather than centered over the pipe, so that any vertical loads transmitted can be resisted more effectively by the main pipe. This also allows steps to be added to the outermost wall with a smooth transition to

the floor. This type can be manufactured in either of two ways: (1.) a short riser section can be attached to the pipe as an integral fitting and successive sections field attached to make up the required riser height, or (2.) if the riser length is not excessive, say 10 ft or less, it can be fabricated with a short length of main pipe and installed as a unit.

For either type of construction, where the riser has a total height of 10 ft or more, a slip joint should be included in the riser section. Locate the slip joint about 2 ft above the main line. This will help avoid excessive vertical loads being transmitted from the riser to the main line. Figure 4 shows an example of a simple riser slip joint. Wooden spacers are used to keep the joint in the extended position during installation and backfilling. After the soil is compacted the spacers should be removed. Other types of slip joints may also be used.

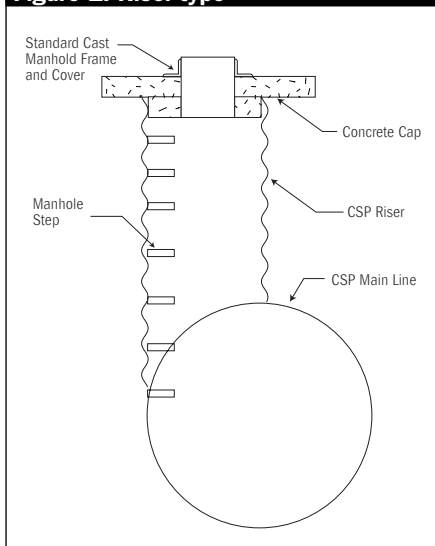
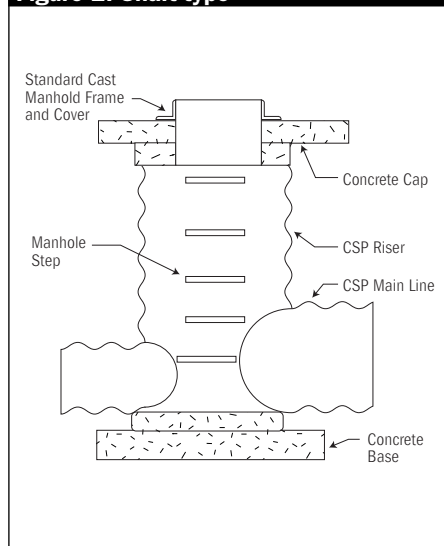
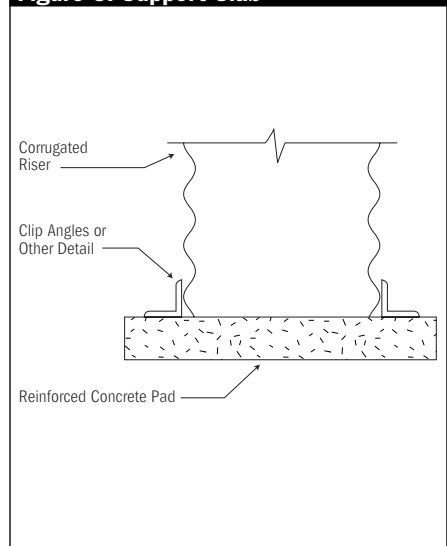
Figure 1. Riser-type**Figure 2. Shaft-type****Figure 3. Support Slab**

Figure 4. Riser Slip Joint

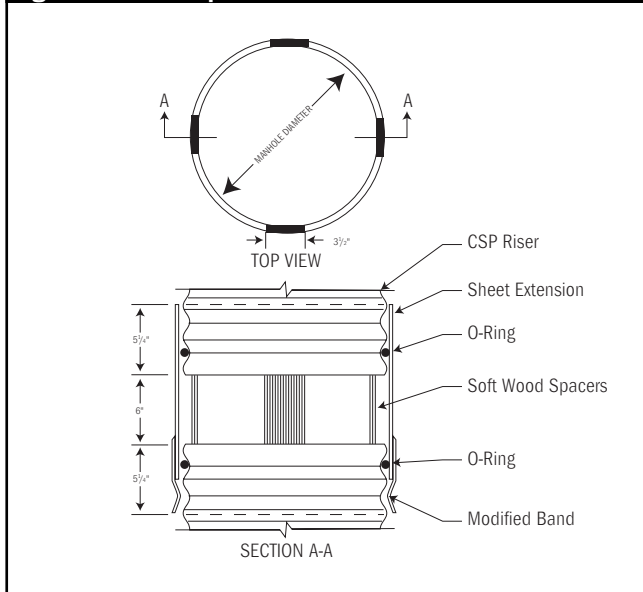
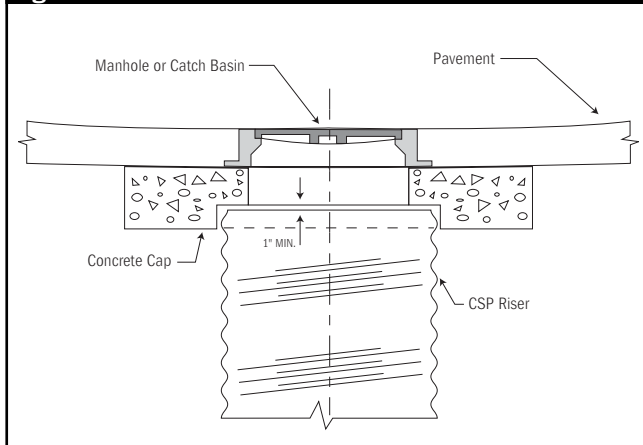


Figure 5 shows typical details used to accommodate manhole covers or grates. In both cases, the concrete cap should be designed (by the specifying agency) with a bearing area sufficient to transfer the dead weights (such as cap, grate, or manhole cover) and any vehicular loads (such as H20 live loads) directly to the soil rather than to the riser. The required bearing area will depend on the allowable soil bearing pressure. Also, install the cap to provide a clearance of about 1 in. between the cap and the riser to allow for settlement.

Where a penetration is made in the main line for a riser, the need for reinforcement must be considered. Generally, the need for reinforcement increases with increasing fill height, increasing diameter, and decreasing wall thickness. As a guide, refer to NCSA Design Data Sheet No. 18A, "Pipe Reinforcement at Fittings and Intersections," and ASTM A998, "Structural Design of Reinforcements for Fittings in Factory-Made Corrugated Steel Pipe for Sewers and Other Applications." A computer program, CSPFIT, is also available from NCSA to automate reinforcement calculations.

Figure 5. Manhole Cover Detail



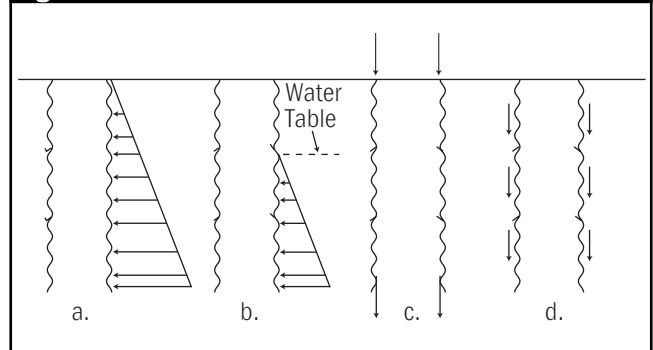
In determining reinforcement needs from these references, treat the riser as a branch pipe. The effect of any vertical loads transmitted to the pipe by the riser must be investigated separately. However, if the above recommendations are followed regarding the use of riser slip joints and adequate concrete cap bearing area, vertical loads should be small.

Where manholes penetrate concrete paving slabs, it may also be necessary to investigate the strength of the slab at that location. Generally, any weakening of the slab caused by the penetration can be overcome by adding additional steel reinforcement in the slab adjacent to the hole.

Loadings to Consider

Figure 6 illustrates potential lateral and vertical loads on manholes. In the following discussion, the term *riser* refers to both the riser portion of a riser-type manhole and the shaft portion of a shaft-type manhole.

Figure 6. Loads on Manholes



Lateral loads on the riser (or shaft) can be estimated from the active lateral soil pressure, which is a function of the vertical pressure adjacent to the liner due to earth load, water load, and surface live loads. The riser should be designed for this external pressure, just as if it were a horizontal pipe.

Where the water table is below the riser, the vertical pressure, p_v (psf), at any depth, H (ft), below the ground surface can be calculated from

$$p_v = wH + p_{LL} \quad (\text{Eq. 1})$$

where w (pcf) is the soil density (usually taken as 120 pcf), and p_{LL} is the live load pressure (see AISI Handbook). From the Rankine equation, the lateral load, p_h (psf), at the same depth is

$$p_h = K_a p_v \quad (\text{Eq. 2})$$

where K_a , the active earth pressure coefficient, is expressed in terms of the internal friction angle of the soil, ϕ , by

$$K_a = \frac{1 - \sin\phi}{1 + \sin\phi} \quad (\text{Eq. 3})$$

The angle ϕ and hence K_a varies with soil type and compaction. For average construction conditions, assume $\phi = 30^\circ$ and thus $K_a = 0.33$. In this case, as indicated by Equation 2, the horizontal pressure will be only about 1/3 the vertical pressure.

Where the water table is above the bottom of the riser, the water pressure provides another source of lateral load. In this case the lateral load, p_h (psf), may be calculated from

$$p_h = \gamma_w H_w + K_a \{wH[1-0.33(H_w/H)] + p_{LL}\} \quad (\text{Eq. 4})$$

where γ_w (pcf) is the water density (62.4 pcf), H_w (ft) is the height of the water table above the point of calculation, and the other terms are as previously defined. The term $[1-0.33(H_w/H)]$ converts the normal soil density into its buoyant density.

Vertical loads on the riser that must be considered include surface loads (wheel loads) applied directly over the manhole, the weight of the concrete cap and manhole cover, and the dead load (self weight) of the riser. In some cases, drag-down loads along the barrel of the riser may be important. Vertical loads should be compared to the axial strength of the riser. Also, they should be used to design the base slab for shaft-type manholes.

Vertical wheel loads and the weight of the concrete cap and cover can be neglected where the cap is designed to transmit these loads directly into the soil. Otherwise, include a load of 16,000 lb for AASHTO H20 or 20,000 lb for AASHTO H25. Obtain cap and cover weights from manufacturers data. The riser dead load can be determined from tabulated weights for a variety of corrugation profiles and wall thicknesses (see *AISI Handbook*). The effects of these vertical loads on the main pipe can be neglected when a slip joint is used in the riser near the main pipe.

Dragdown loads develop when the soil surrounding the riser moves downward more than the riser itself, transmitting a vertical load to the riser through friction. Such a condition could arise where fill is placed over compressible subsoils (clays, silts, or peats). A similar condition can arise where the water table is substantially lowered, because the effective den-

sity of the soil in the zone that was previously below the water table increases, thereby inducing settlement. Thus, dragdown loads can develop over time when there is settlement of the soil around the riser relative to settlement of the riser support. Determination of such loads is a site-specific consideration that depends on soil profiles and soil properties.

Information developed on piling can be used as a guide where it is necessary to calculate such loads. The maximum dragdown force that can be developed can be estimated from the following equation (see Merritt, *Standard Handbook for Civil Engineers, McGraw-Hill*):

$$Q_s = p_v \beta A_s \quad (\text{Eq. 5})$$

where Q_s = dragdown force, lbs

p_v = average vertical soil pressure along height of riser, psf

β = 0.20 to 0.25 for clay; 0.25 to 0.35 for silt; and 0.35 to 0.50 for sand.

A_s = surface area of riser, sq. ft = πDH

D = diameter of riser, ft

H = height of riser, ft

This is a version of the so-called β method; β is a function of the effective friction angle and other factors. For a more detailed approach related to specific soil properties, see the AASHTO *LRFD Bridge Design Specifications*.

Vertical (Axial) Strength of Riser

Estimated values of the resistance of risers to end load collapse for different wall profiles and thicknesses are given in Table 1. For a riser of diameter D (in.), multiply the values shown by the circumference (πD or $3.14D$) to obtain the value for that riser. Vertical loads, particularly those caused by surface loads and the riser dead load, should be limited to the axial strength divided by a safety factor of 1.5.

In regard to dragdown forces, the strength of the riser will play a role in determining the magnitude of the load. Essentially, as the corrugations in the riser compress under increasing load, this deformation (decrease in corrugation

Table 1. Axial Strength of Risers (lb/in. of circumference)

Specified Thickness, in.	2 1/2" x 1/2"	3" x 1" 5" x 1"	3/4" x 3/4" x 7 1/2" x 7 1/2"	3/4" x 1 x 11 1/2" x 11 1/2"
0.064	200	100	60	45
0.079	300	150	90	68
0.109	500	250	150	112
0.138	800	400	240	180
0.168	1100	550	330	248



In-Line, Shaft-Type Manhole.

pitch or rib width) tends to relieve dragdown forces because it decreases relative settlement. A dragdown force greater than the strength of the riser cannot be developed. Therefore, the strength of the riser serves as an upper bound on any calculated dragdown force.

Design Examples

Example A

Problem. A 48 in. diameter main line will have 1 to 5 ft of cover and be subjected to H20 highway loadings. It will have a $2\frac{1}{2} \times \frac{1}{2}$ in. profile with a specified thickness of 0.064 in. The water table is below the top of the main line. Dragdown conditions are not anticipated because of the modest depth of cover and the uniformity of soil type within this depth. The backfill will have a compacted unit weight of 120 pcf and an internal friction angle of 30 degrees. Determine the required wall thickness for a 36 in. diameter riser of the same profile, and check reinforcement requirements for the main line.

Lateral Loads. At 1 ft of cover the vertical live load is 1800 psf, and the earth load is 120 psf (1 ft x

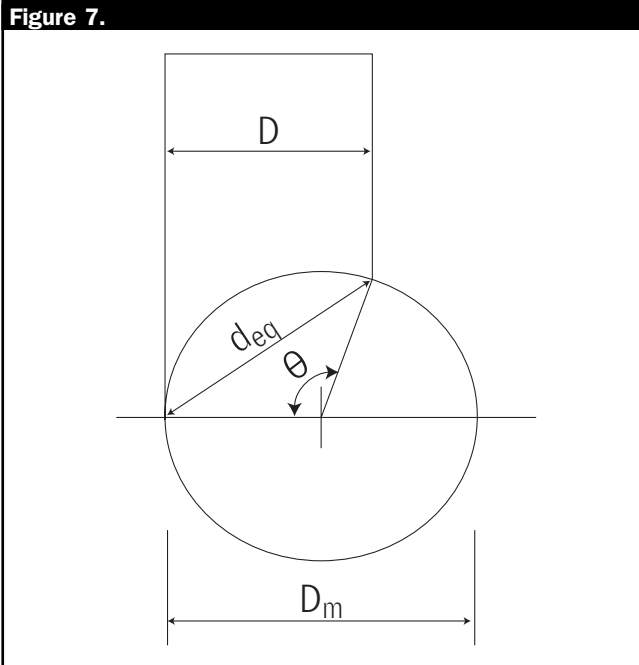
120 pcf), so the total vertical pressure is 1920 psf. At 5 ft of cover the vertical live load is 200 psf and the earth load is 600 psf (5 ft x 120 pcf), so the total vertical pressure is 800 psf. Using the greater value of 1920 psf, and Equations 2 and 3, the horizontal pressure is 634 psf ($P_h = 0.33 \times p_v = 0.33 \times 1920$ psf). A check using ASTM A796, AASHTO Specifications, or AISI Handbook tables, shows that a specified thickness of 0.064 in. meets all structural requirements for this loading consideration. Note that the 634 psf lateral pressure is equivalent to a height of cover on a horizontal pipe of 5.3 ft (634 psf / 120 pcf). Thus, a standard fill height table can be used with the 5.3 ft equivalent height of cover to rapidly determine the required thickness.

Vertical Loads. From tables in the AISI Handbook, a metallic coated 36 in. diameter pipe, $2\frac{1}{2} \times \frac{1}{2} \times 0.064$ in., weighs 29 lb/ft. Assuming a riser height of 6 ft (5 ft plus $\frac{1}{4}$ the main line diameter = 5 + (48 / 12) / 4), the riser weight is 174 lb (6 ft x 29 lb/ft). If the manhole top details are estimated to have a weight of 1000 lb, the total dead load is 1174 lb (174 lb + 1000 lb). If the concrete cap at the top of the riser is not designed to transmit the top loads directly to the soil, an H20 wheel load of 16,000 lb must be accommodated. In this case the dead load plus live load would be 17,174 lb (1174 lb + 16,000 lb).

From Table 1, the axial strength of a $2\frac{1}{2} \times \frac{1}{2} \times 0.064$ in. riser is 200 lb/in., which results in a total axial strength of 22,608 lb (3.14 x 36 in. x 200 lb/in.). The safety factor would then be 1.32 (22,608 / 17,174), which is less than the desired value of 1.5. A riser with a 0.079 in. wall thickness weighs 36 lb/ft and has a vertical strength of 300 lb/in. of circumference, so the total axial strength is 33,912 lb (3.14 x 36 in. x 300 lb/in.). The total dead plus live load would be 17,216 lb (36 lb/ft x 6 ft) + 1,000 lb + 16,000 lb). The safety factor



Offset, Shaft-Type Manhole on a Slab.



Placing Riser Section on Pipe Stub.

would be 1.97 (33,912 / 17,216), which exceeds the desired value of 1.5. Therefore, if the concrete cap at the top of the riser is designed to transmit the top loads directly to the soil, select a 0.064 in. wall riser. Otherwise, select a 0.079 in. wall riser. The ability of the main pipe to withstand the vertical load is considered below.

Reinforcement Check. Assume the riser is located on the main line pipe as indicated in Figure 1. With reference to Figure 7, the maximum opening in the main pipe (chord distance) for a riser of diameter D (in.) will be the same as the opening for an equivalent 90° branch pipe with an equivalent diameter, d_{eq} (in.), given by

$$d_{eq} = D_m \times \sin(\theta/2) \tag{Eq. 6}$$

where D_m (in.) is the main line diameter and θ is the subtended angle calculated from

$$\cos\theta = \frac{(D_m/2) - D}{D_m/2} = 1 - 2 \frac{D}{D_m} \tag{Eq. 7}$$

For this example, $D_m = 48$ in. and $D = 36$ in. From Equation 7 calculate $\theta = 120^\circ$ and from Equation 6 calculate $d_{eq} = 41.6$ in. A check using ASTM A998 or the computer

program CSPFIT, using a rounded-up branch diameter of 42 in. and a branch angle of 90° , shows that reinforcement of the main pipe is not required for the usual loadings. However, the effects of the vertical riser loads must also be considered if the concrete cap at the top of the riser is not designed to transmit the top loads directly to the soil. The following approximate analysis may be used.

The riser load induces circumferential bending moments in the main pipe. The riser load is assumed to be uniformly distributed over its diameter when viewed in the cross section of the main pipe. Ring deflection induces horizontal passive pressures in the soil to resist the deflection, and these pressures are assumed to be uniformly distributed over a zone that subtends an angle of 120° on the main pipe for all cases. With these assumptions, the bending moment M (in. lb) in the main pipe at its horizontal diameter is

$$M = (-0.250KPD_m^2/D) + (0.0717PD_m) \tag{Eq. 8}$$

where P (lb) is the total riser vertical load, D_m (in.) is the main line diameter, D (in.) is the branch diameter, and K is a moment coefficient that depends on the value of θ calculated from Equation 7. Values of K may be selected from Table 2 (interpolate for intermediate values).

Table 2. Moment Coefficient K, Based on Equivalent Diameter Angle θ

θ	30	45	60	90	120	135	150	180
K	0.00663	0.0265	0.0633	0.1628	0.2315	0.2448	0.2492	0.2500

(See W. C. Young, *Roark's Formulas for Stress and Strain*, McGraw-Hill, 1989.)

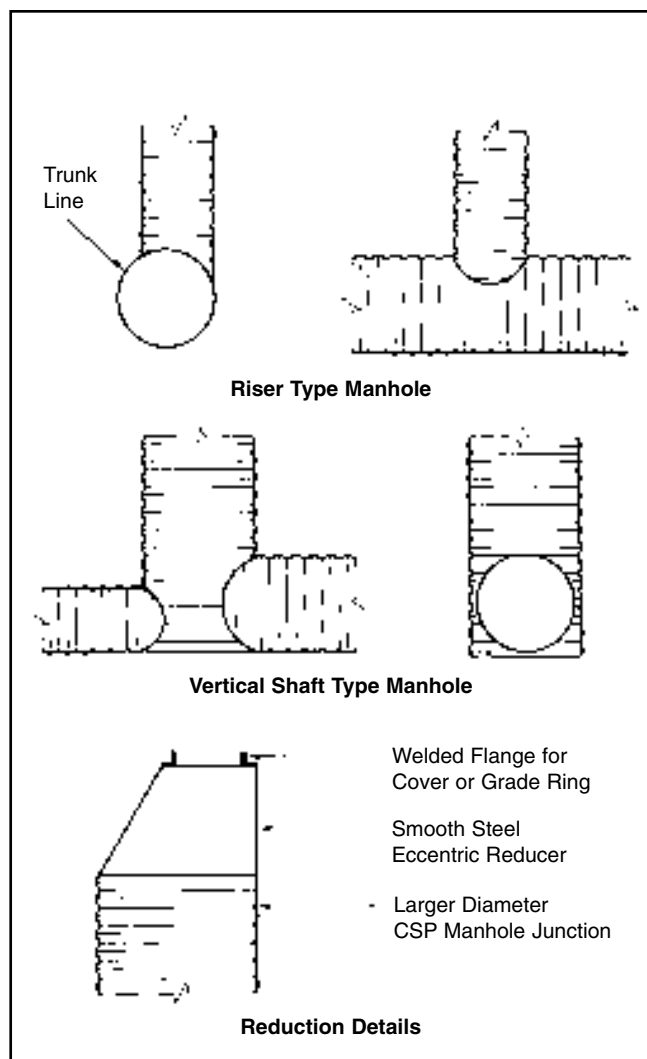
The ring bending stress, f (psi), is

$$f = M/S \quad (\text{Eq. 9})$$

where S (in^3) is the section modulus of the effective ring width. This width is assumed to equal the riser diameter. The stress f (psi) should be limited to 20,000 psi.

For this example, $\theta = 120^\circ$, $K = 0.2315$, $P = 17,216$ lb, $D_m = 48$ in., and $D = 36$ in. From Equation 8 calculate $M = -63,768 + 59,251 = 4517$ in. lb. From the AISI Handbook, the section modulus, S , for the $2\frac{3}{8} \times \frac{1}{2} \times 0.079$ in. profile is $0.0998 \text{ in}^3/\text{ft}$ or 0.2994 in^3 for a width equal to the riser diameter (3 ft). From Equation 9, the bending stress f is 15,087 psi ($4517 \text{ in. lb} / 0.2994 \text{ in}^3$). Therefore, the main pipe does not have to be reinforced for the vertical riser loads.

Where larger diameters and/or greater loads are involved, it may be necessary to attach a circumferential stiffening ring to the main pipe adjacent to the riser on each side. To check the stress in this case, calculate the section modulus for a section comprised of the two rings and the corrugated sheet between, and use this for S .



Example B

Problem. A 48 in. diameter shaft-type manhole with a total height of 9.5 ft is required. Dragdown conditions are anticipated because fill will be placed over compressible subsoils. The silty-sand backfill will have a compacted unit weight of 120 pcf and an internal friction angle of 30° . Because of the compressible soil, the top loads will be assumed to be resisted entirely by the riser. Determine the required wall thickness for the manhole assuming the $2\frac{3}{8} \times \frac{1}{2}$ in. corrugation profile. Also determine the required footing pad size based on an allowable soil bearing pressure of 4000 psf.

Lateral Loads. Maximum conditions are generated at the 9.5 ft depth. At 9.5 ft cover the vertical live load is negligible. The earth load is 1140 psf ($9.5 \text{ ft} \times 120 \text{ pcf}$), so the total vertical pressure is 1140 psf. The horizontal pressure can be calculated using Equations 2 and 3 to be 376 psf ($0.33 \times 1140 \text{ psf}$). The 376 psf lateral pressure is equivalent to 3.1 ft ($376 \text{ psf} / 120 \text{ pcf}$) height of cover on a horizontal pipe. A check using ASTM A796, AASHTO Specifications, or AISI Handbook tables, shows that a specified thickness of 0.064 in. meets all structural requirements for this loading consideration.

Vertical Loads. A preliminary check shows that a riser wall thickness of 0.064 or 0.079 in. is inadequate for the vertical loads. Therefore, check a 0.109 in. wall thickness riser. From tables in the AISI Handbook, a metallic coated 48 in. diameter pipe with a $2\frac{3}{8} \times \frac{1}{2}$ in. corrugation and a 0.109 in. wall thickness weighs 65 lb/ft. The riser weight is 618 lb ($65 \text{ lb/ft} \times 9.5 \text{ ft}$). Estimate the top load as 1000 lb and include 16,000 lb for an H20 wheel load.

The dragdown force, Q_s , may be calculated from Equation 5 as follows:

$$p_v = \text{average vertical soil pressure along height of riser} \\ = 1140 \text{ psf} \times \frac{1}{2} = 570 \text{ psf}$$

$$A_s = \text{surface area of riser} \\ = 3.14 \times 4 \text{ ft dia.} \times 9.5 \text{ ft height} = 119 \text{ sq. ft}$$

$$\beta = 0.35 \text{ (estimate based on backfill material)}$$

Substituting these values,

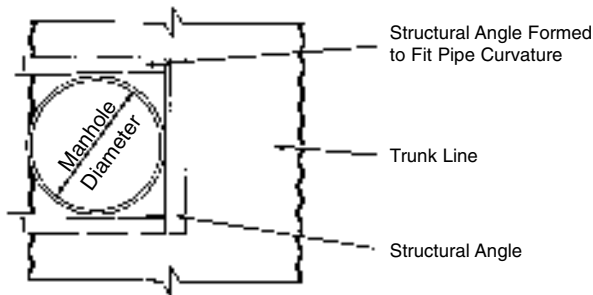
$$Q_s = p_v \beta A_s = 570 \times 0.35 \times 119 = 23,740 \text{ lb.}$$

The total load, Q_s , including the dragdown load, riser dead load, top load and wheel load, is 41,358 lb ($23,740 \text{ lb} + 618 \text{ lb} + 1000 \text{ lb} + 16,000 \text{ lb}$).

From Table 1, the axial strength of a riser with a 0.109 in. wall is 500 lb/in., so the total axial strength is 75,360 lb ($3.14 \times 48 \text{ in.} \times 500 \text{ lb/in.}$). The safety factor would be 1.82 ($75,360 \text{ lb} / 41,358 \text{ lb}$), which exceeds the desired minimum value of 1.5.

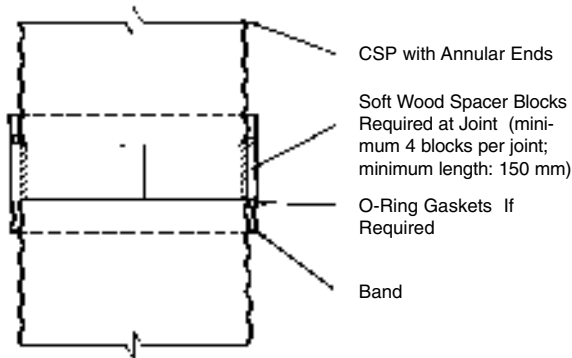
The required area of the footing is 10.3 sq. ft (41,358 lb / 4000 psf). Consider a square footing, 5 ft by 5 ft. This will provide a bearing area of 25 sq. ft, which exceeds the required 10.3 sq. ft minimum. As an alternative, the footing can be constructed with a circular void, in the center, having a diameter about 1 ft less than that of the riser. In this case, if the void is 3 ft in diameter, the net area of the footing would be 17.9 sq.ft ($25.0 - 3.14 \times 3^2/4$), which also provides the required minimum bearing area.

Manhole Reinforcing



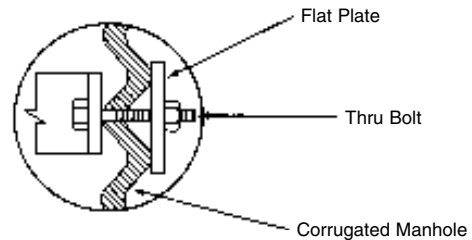
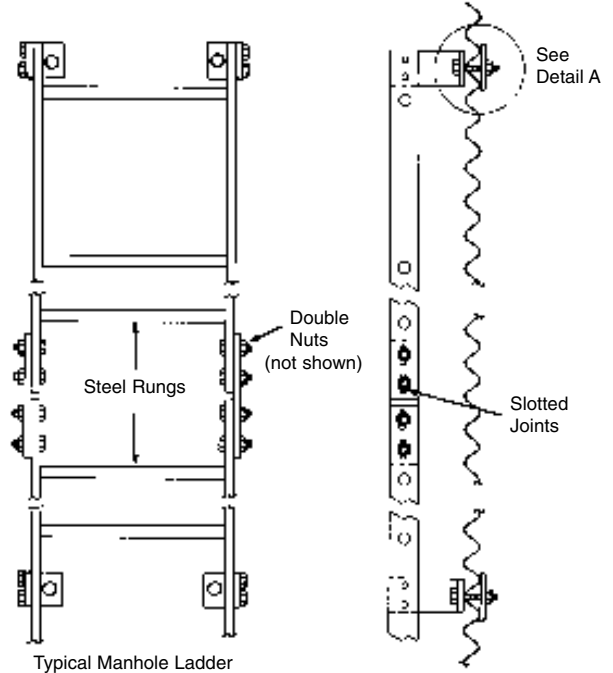
Use of manhole reinforcing is recommended when trunk line sewer pipe size is 1600 mm diameter and larger.

Manhole Slip Joints



Heavily loaded manholes sometimes make slip joints desirable. Shown above is one method of providing a slip joint, which allows settlement in the riser.

Manhole Ladder



Typical Ladder Bracket Attachment

1. Ladder may be constructed in one length.
2. Use bolts with double nuts to connect splice plate at ladder joint to allow vertical movement.
3. Hot-dip galvanizing of all ladder components is recommended.



Ladder Mounted on Riser.

Design Data Sheets

- **DESIGN DATA SHEET #12** (PUB # 08-412) (1985; 4 pgs.)
Typical steel headwall designs; includes diagrams, photos.
- **DESIGN DATA SHEET #13** (PUB # 08-413) (1988; 4 pgs.)
Stormwater detention systems; illustrated with chart for volume in cubic feet per linear foot of pipe-arch included.
- **DESIGN DATA SHEET #14** (PUB # 08-414) (1988; 4 pgs.)
Using perforated CSP for recharging storm runoff; includes design & construction explanation of one type of recharge trench.
- **DESIGN DATA SHEET #15** (PUB # 08-415) (1991; 4 pgs.)
Underground detention chambers as well as combination underground detention and recharge systems and their application to National Pollutant Discharge Elimination System; illustrated.
- **DESIGN DATA SHEET #16** (PUB # 08-416) (1991; 8 pgs.)
Rehabilitation methods for storm sewers and culverts by sliplining, cement mortar lining, inversion lining and in-place installation of a concrete invert; illustrated with photos and diagrams.
- **DESIGN DATA SHEET #17** (PUB # 08-417) (1993; 2 pgs.)
Water quality stormwater structures; includes diagram of a typical three chamber design.
- **DESIGN DATA SHEET #18** (PUB # 08-418)
(UPDATED 1999; 12 pgs.)
"Pipe Reinforcements at Fittings and Intersections." Design procedures for analysis and designing fittings reinforcement for CSP stormwater detention systems. Conforms to ASTM A998.
- **DESIGN DATA SHEET #19** (PUB # 08-419) (1995; 12 pgs.)
Load rating and structural evaluation of in-service, corrugated steel structures. The general outline supports the engineer in combining field inspection requirements of the FHWA Culvert Inspection Manual as the basis for analytical evaluations of the AASHTO Standard Specification for Highway Bridges.

Computer Software

- **UNDERGROUND DETENTION DESIGN SOFTWARE**
(PUB # 08-801) (3-1/2" disk, DOS format; 12 pg. user manual)
Computerizes the procedures demonstrated at NCSA Stormwater Management Seminars. Will develop the inflow hydrograph; the stage-storage relationship; the stage-discharge relationship; and route the inflow hydrograph to obtain the outflow hydrograph.
- **LEAST COST ANALYSIS COMPUTER PROGRAM**
(PUB # 08-802) (1992; 21 pgs. plus 3-1/2" disk, DOS format)
Analyzes up to three (3) pipeline alternatives and ranks them on the basis of their total present value. The program can save up to 20 analyses so that they can be retrieved, re-run, changed, etc.
- **FINAL REPORT, CONDITION & CORROSION SURVEY OF CORRUGATED STEEL STORM SEWER & CULVERT PIPE**
(PUB # 08-803) (March 1991; 36 pgs. plus 3-1/2" disk)
Updates the two Interim Reports and provides a complete final analysis of the soil side durability of plain galvanized CSP. Includes an IBM PC compatible statistical model floppy disk to predict the average service life of such pipe based on exterior corrosion.

AVAILABLE NOW FROM



National
Corrugated
Steel Pipe
Association

1255 Twenty-Third Street, NW
Washington, DC 20037-1174
Phone: 202.452.1700
Fax: 202.833.3636
E-mail: csp@ncspa.org
Web: www.ncspa.org